

STORAGE SOLUTIONS

RACKING SYSTEMS

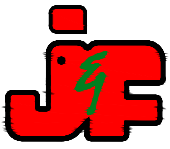

RACKING FOR PALLETISED AND NON-PALLETISED LOADS



View of Racking Systems and storage illustrations

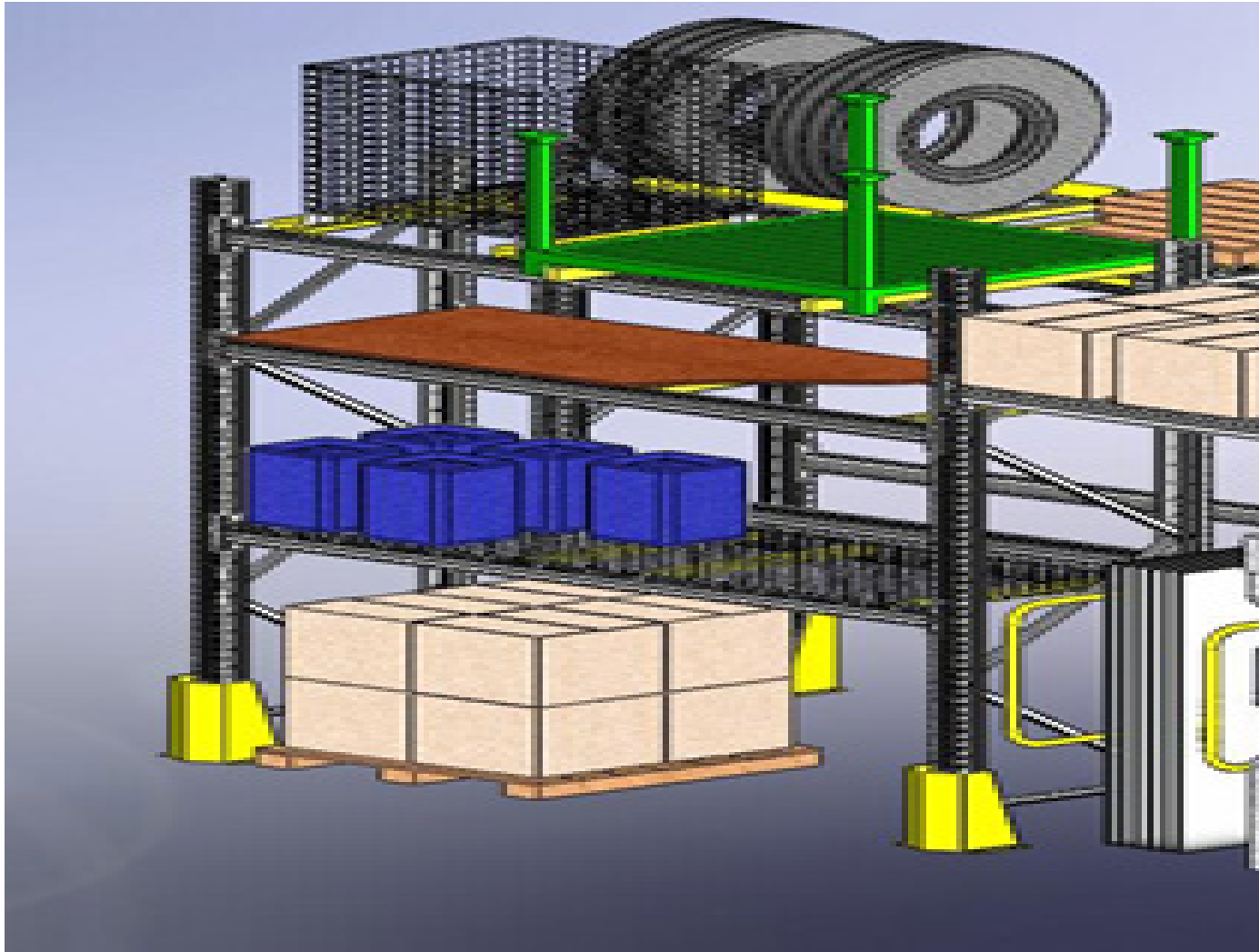

The most extensive range of racking systems and powerful profile constructions

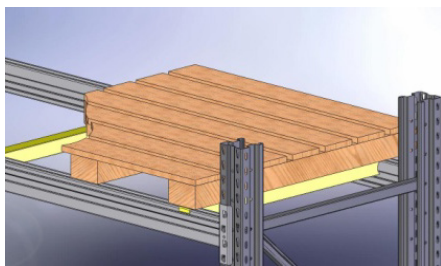

For pallet
Đặt Ba lét

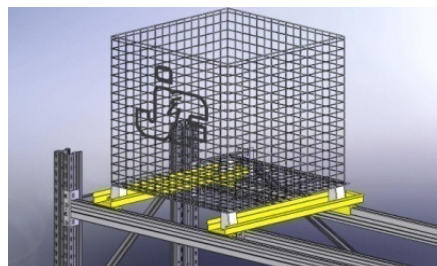

For wire mesh container
Đặt lồng trữ hàng

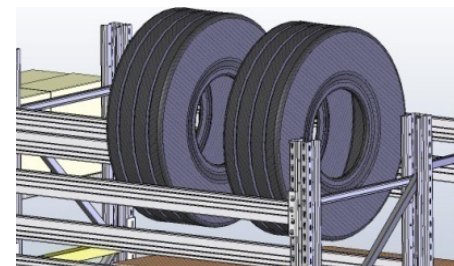

For tire
Đặt vỏ xe

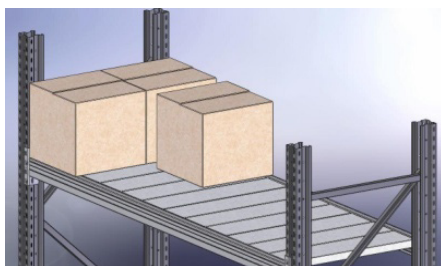

With steel deck for loose cargo
Lót tấm sắt để trữ hàng

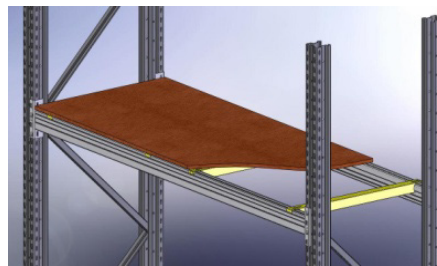

With wood plate for loose cargo
Lót tấm gỗ để trữ hàng

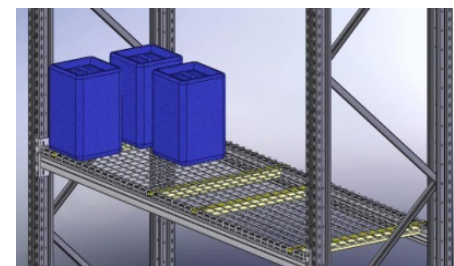

With wire mesh for loose cargo
Lót tấm lưới để trữ hàng

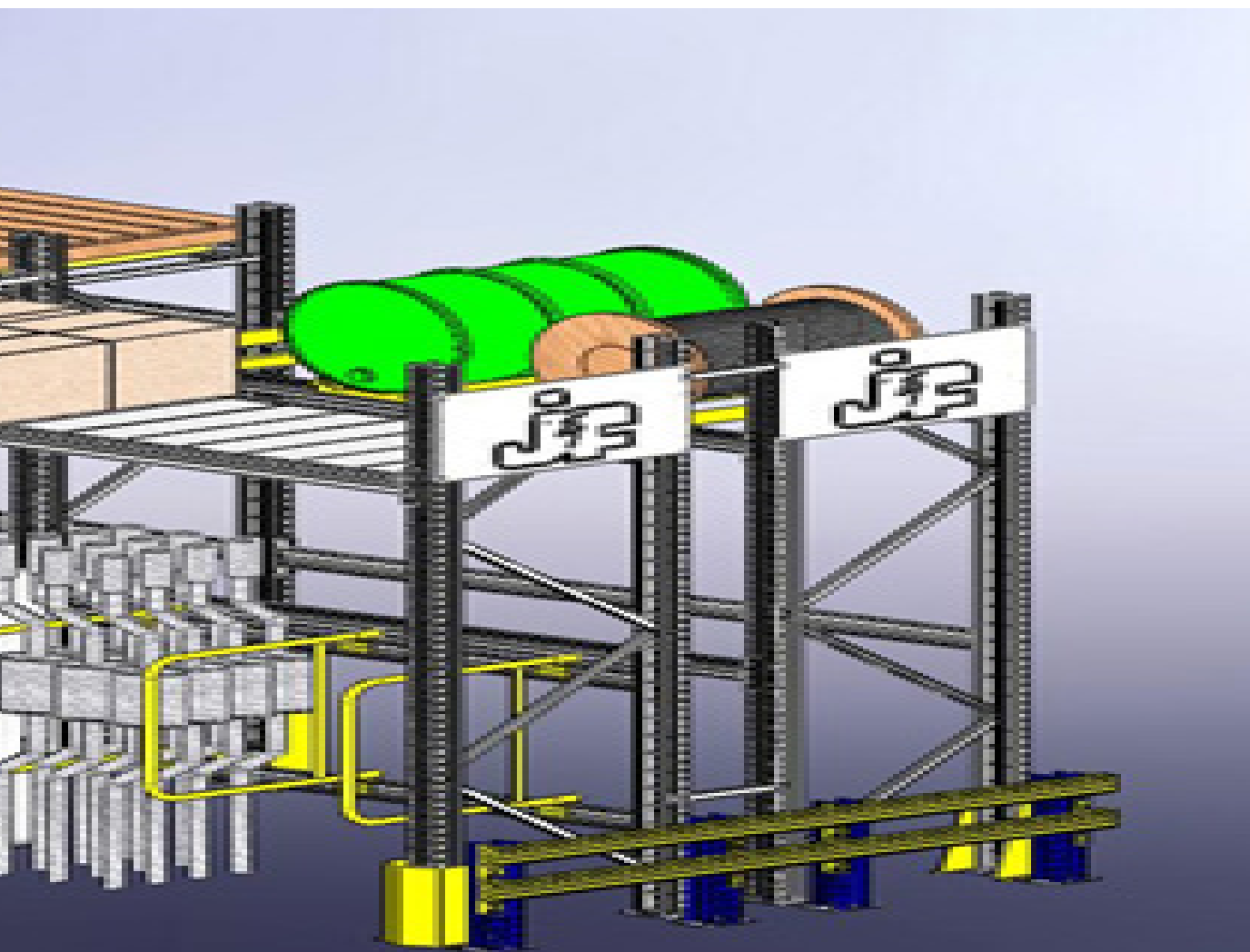
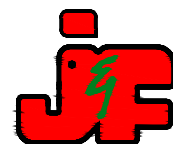

Hệ thống kệ trữ hàng đa năng có kết cấu vững chắc

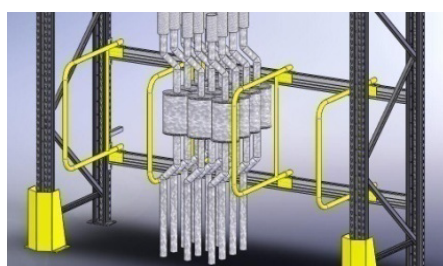

For motor parts
Đặt linh kiện ô tô

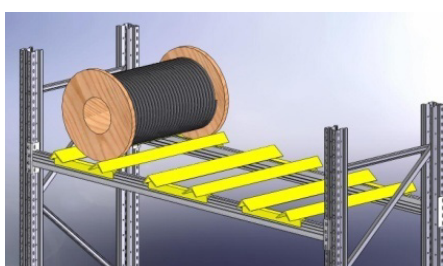

For cable axis
Đặt trụ gỗ dây cáp điện

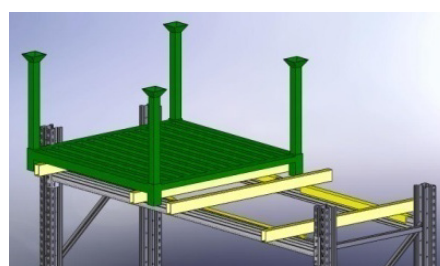

For stacking frame
Đặt tấm kệ frame

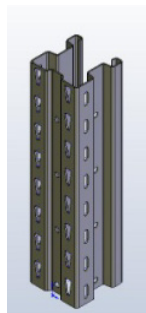

100 x 100



100 x 85

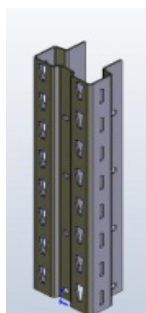

100 x 70

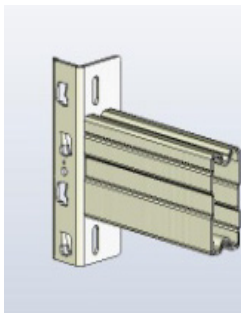

100H

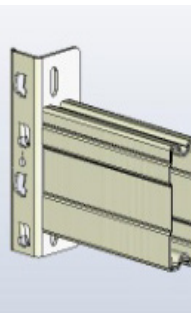

125H

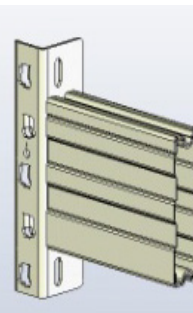

150H

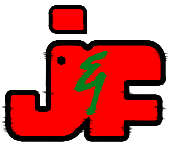

Selective Racking Systems



Case: Textile and Garment
Dự án: Dệt may

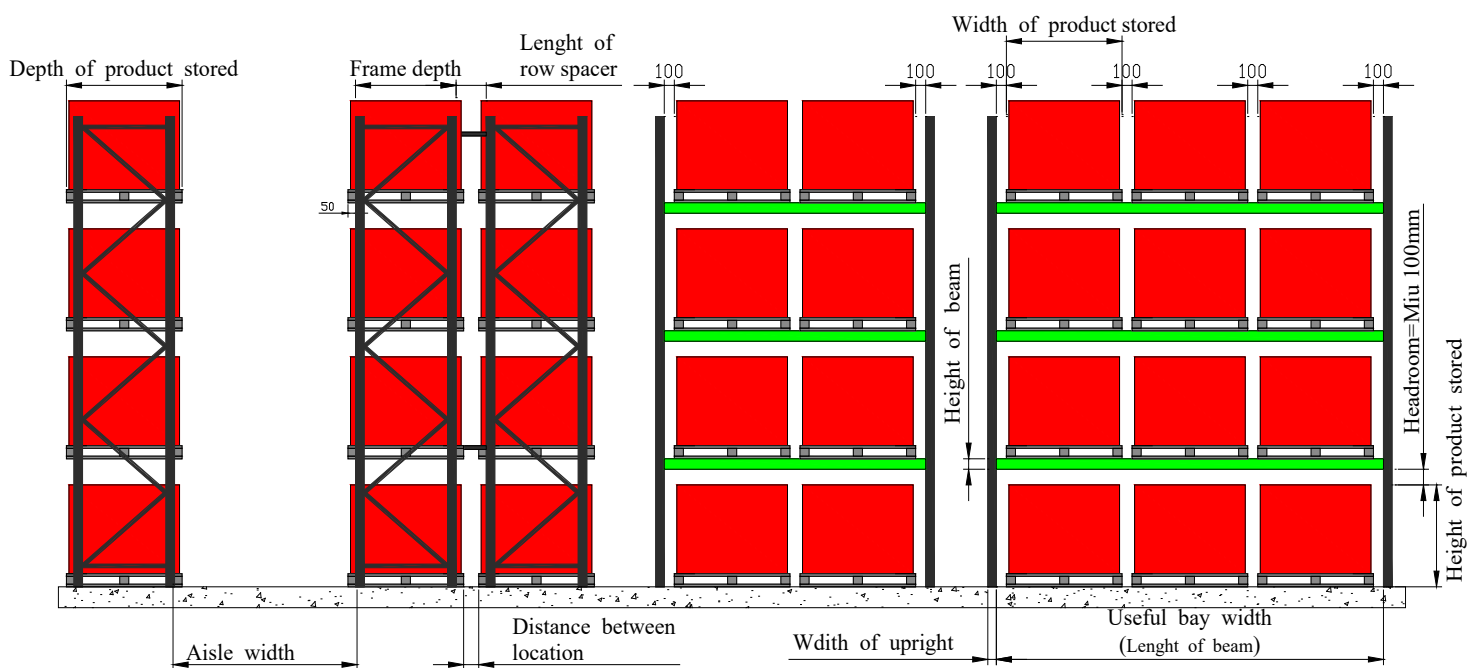



Case: Textile and Garment
Dự án: Dệt may

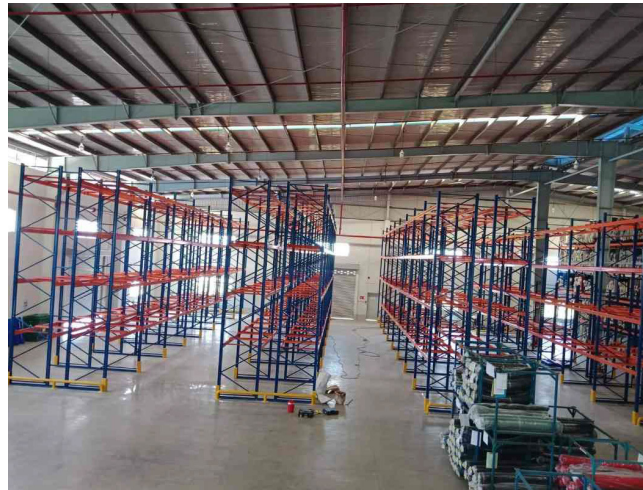

Case: Textile and Garment
Dự án: Dệt may



Case: Footwear
Dự án: Da giày



Case: Textile and Garment
Dự án: Dệt may



Case: Footwear
Dự án: Da giày



Case: Footwear
Dự án: Da giày

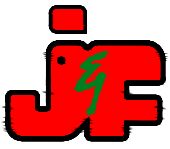

Drive in / through Racking Systems



Case: Furniture
Dự án: Nội thất



Case: Hygiene products
Dự án: Chế phẩm vệ sinh

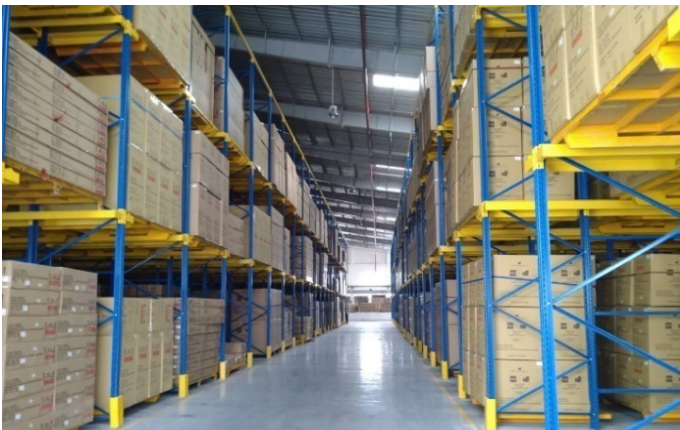

Case: Furniture
Dự án: Nội thất

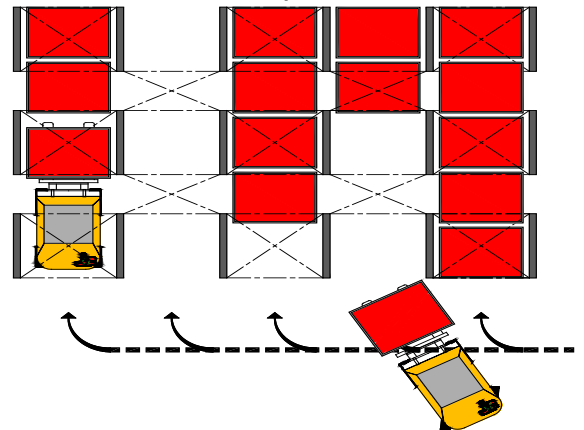



Case: Furniture
Dự án: Nội thất



Case: Furniture
Dự án: Nội thất



Case: Furniture
Dự án: Nội thất

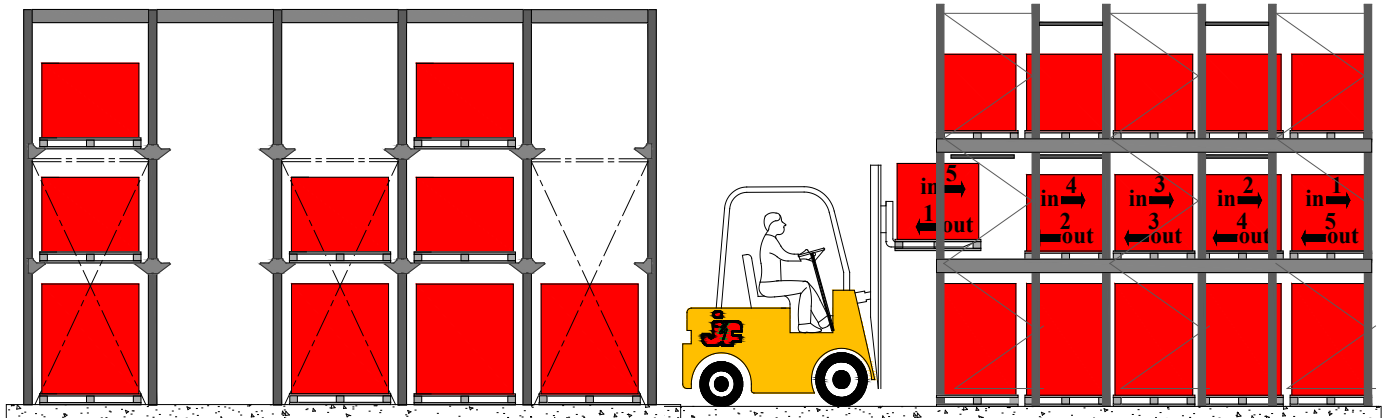

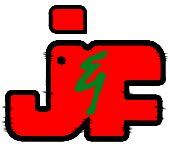

Very Narrow Aisle Racking Systems



Case: Furniture
Dự án: Nội thất

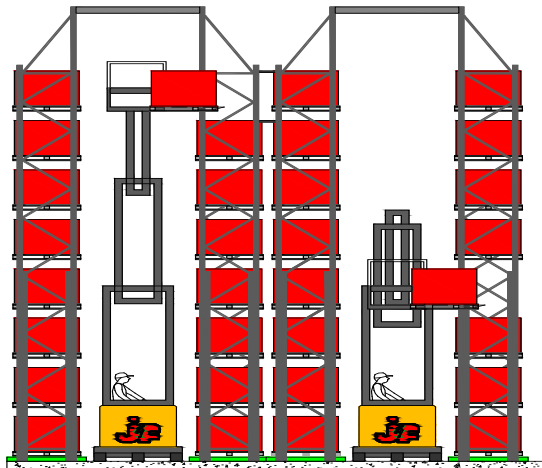

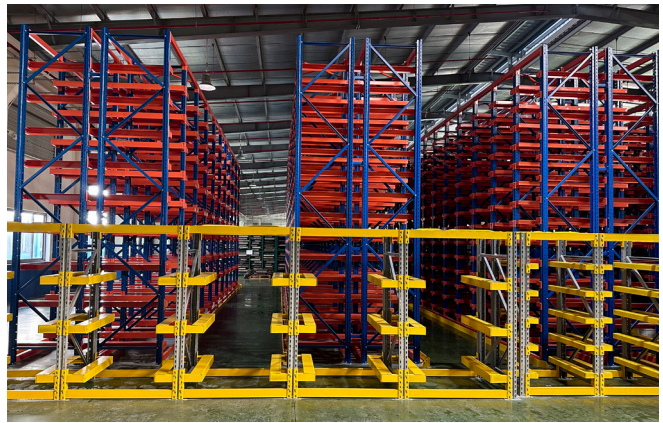
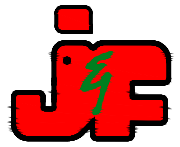

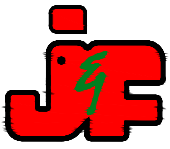

Push Back Racking Systems



Case: Chemical
Dự án: Hóa chất

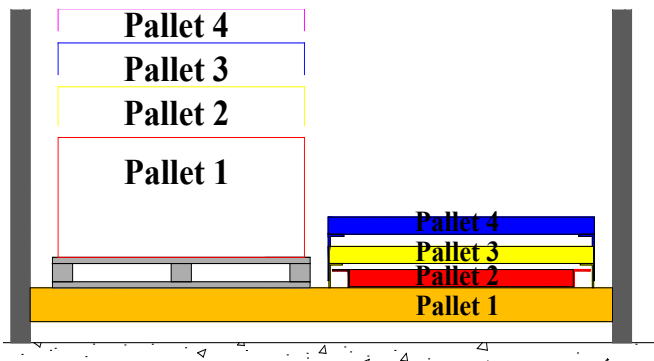



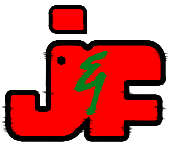

Live Storage Racking Systems / Kệ trữ hàng có ba lết dạng trượt



Front view
Hình mặt trước



Back view
Hình mặt sau



Side view
Hình mặt bên

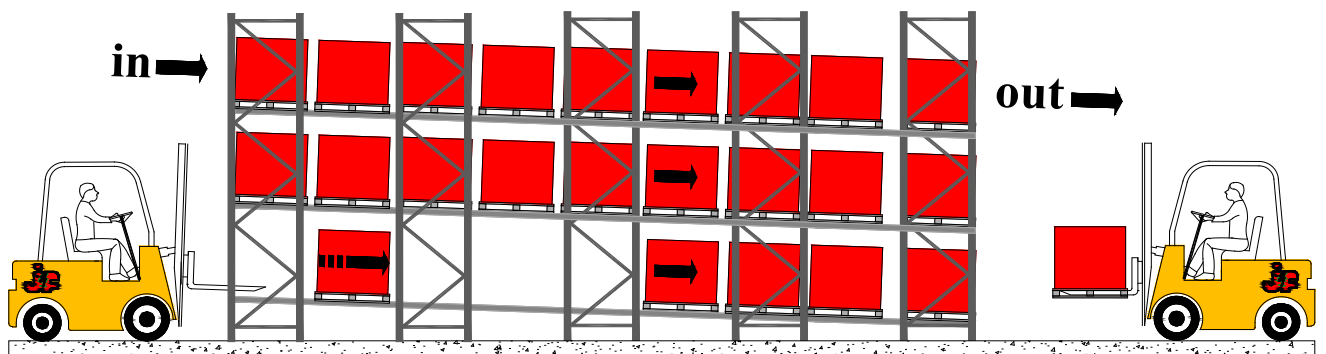



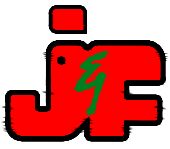

Double Deep Racking Systems / Hệ trữ hàng dạng ba lết đôi



Case: Textile and Garment
Dự án: Dệt may

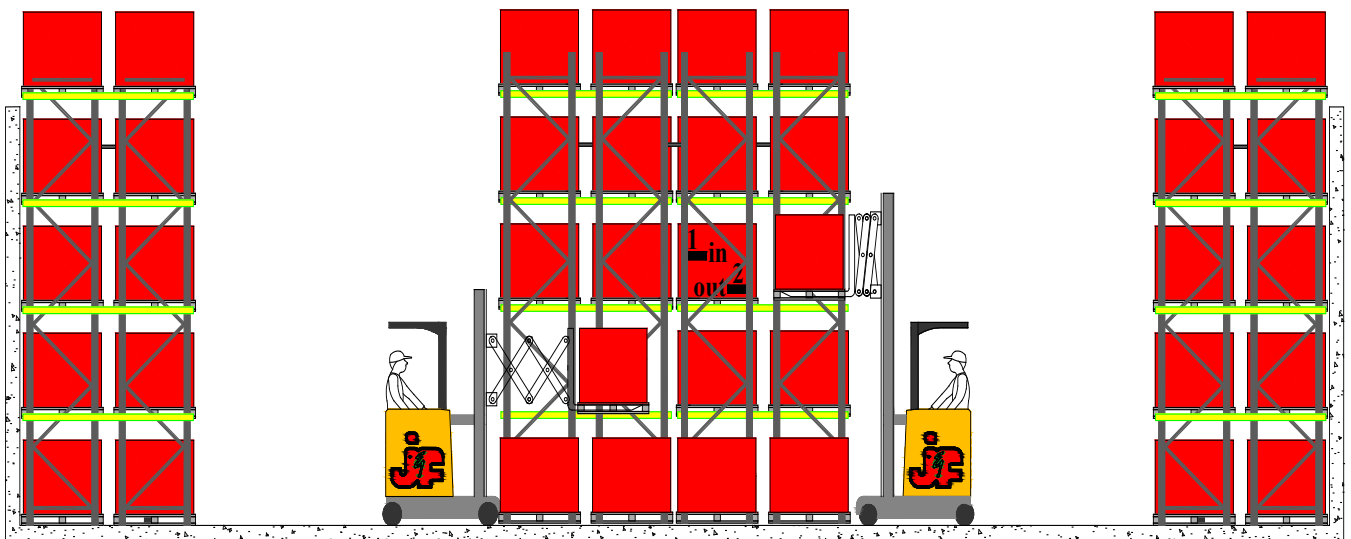

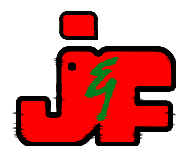

AS/RS Racking Systems / Hệ trữ hàng dạng lưu trữ và truy hồi tự động

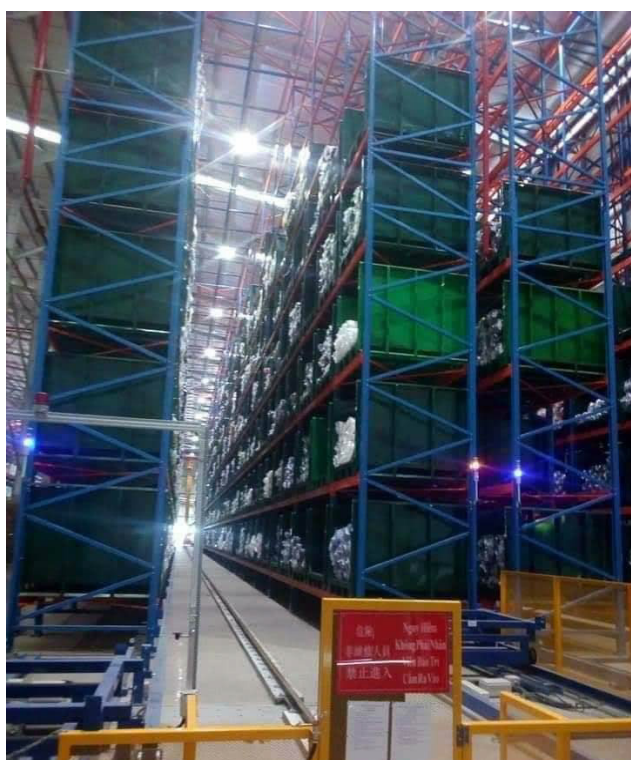

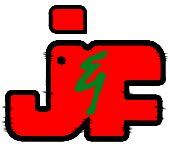

Cantilever Racking Systems



The best storage solutions for long shape goods
Dạng chứa tốt nhất cho vật có kích thước dài

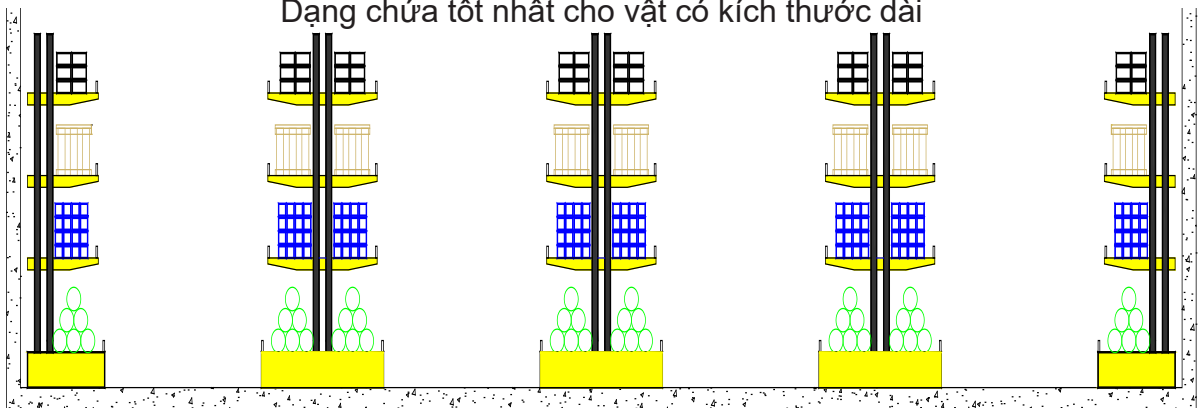

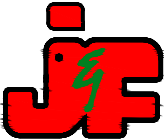

Case: Hardware tools
Dự án: Ngũ kim

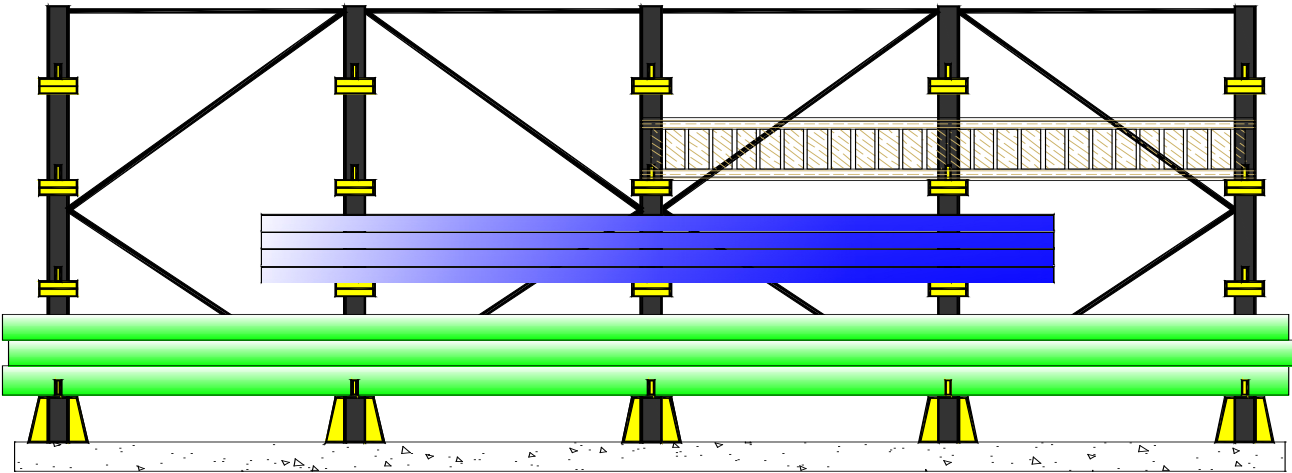

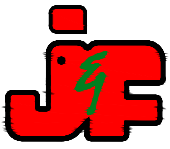

Comparisons of static and mobile racking systems
So sánh giữa kệ trữ hàng Dạng cố định và Dạng di động

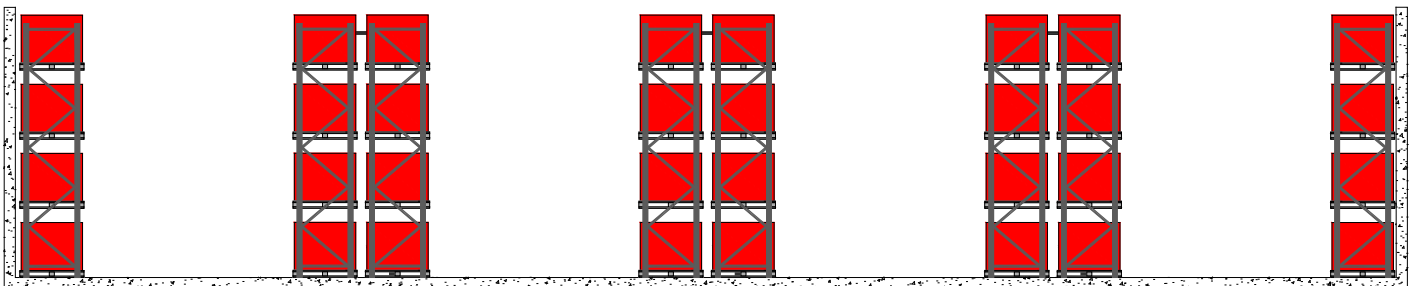

Static racking systems
Kệ trữ hàng dạng cố định

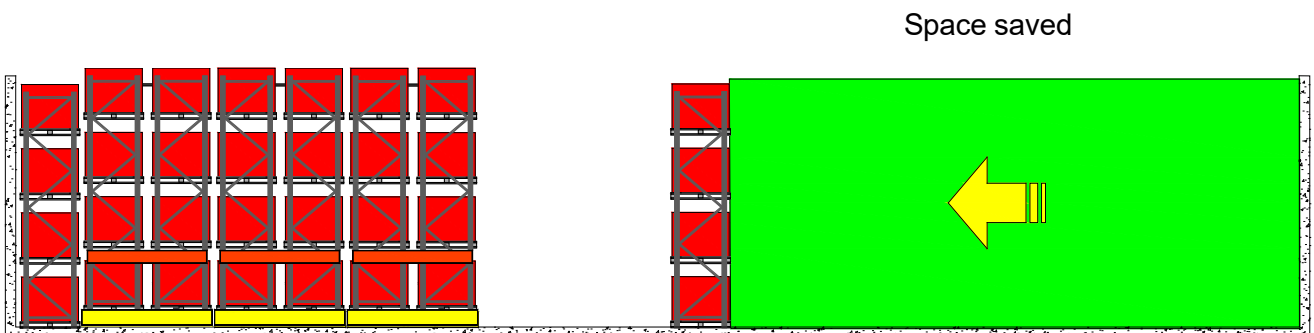

Mobile racking systems save approximately 50% of space
Kệ trữ hàng di động tiết kiệm khoảng 50% không gian

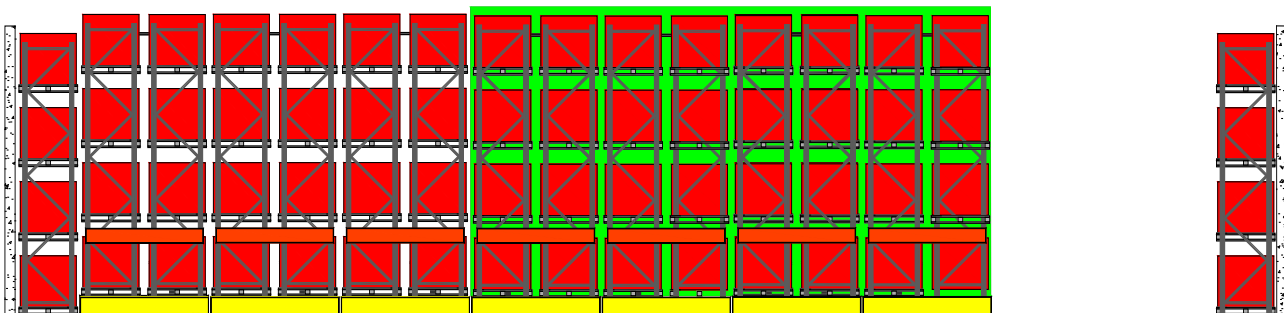
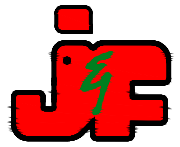

Mobile racking systems create approximately a double warehouse capacity
Kệ trữ hàng dạng di động có thể tạo được lượng trữ hàng gấp đôi

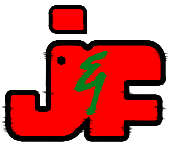

Mezzanine

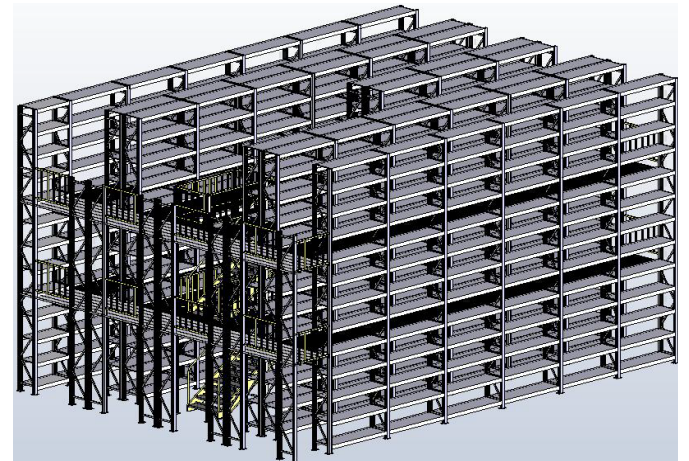
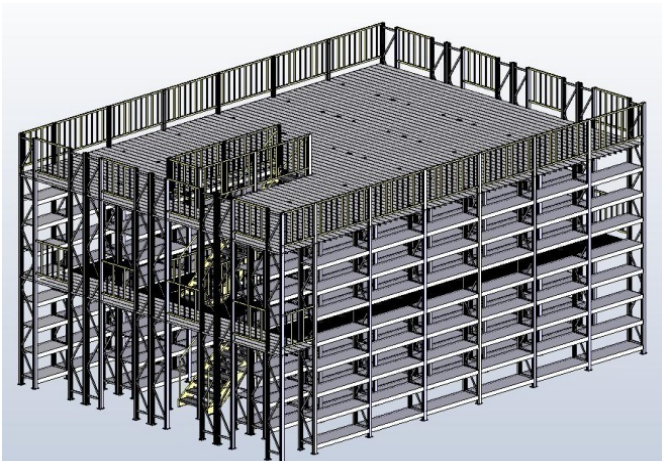

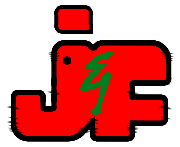

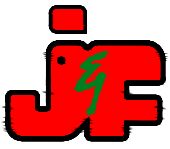

Platform

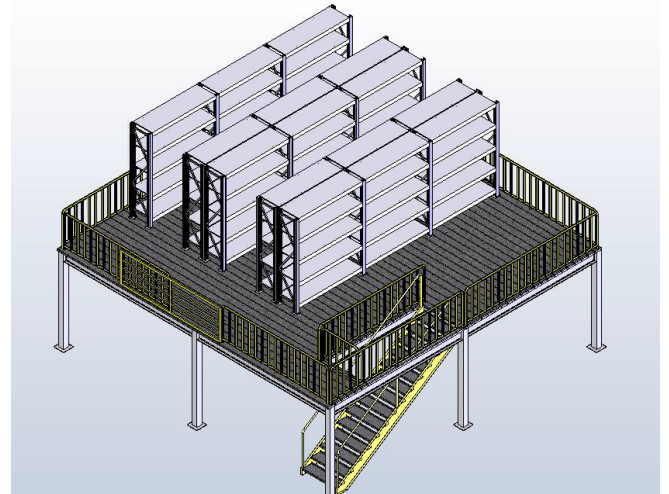
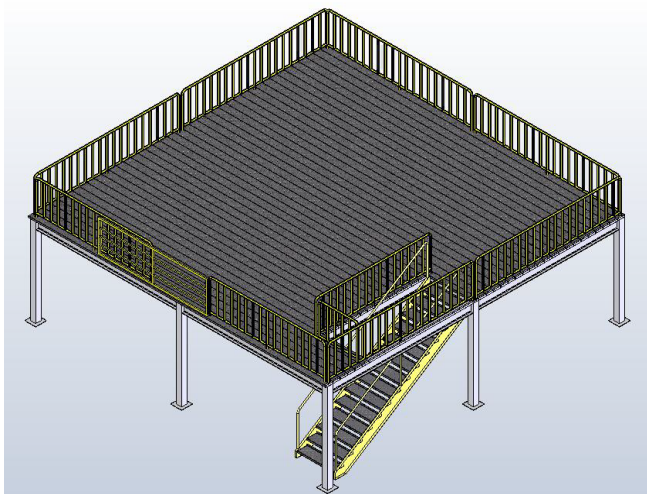

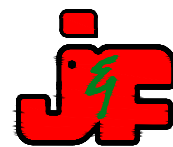

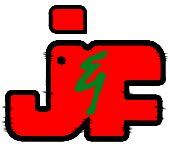

Non standard storage illustrations



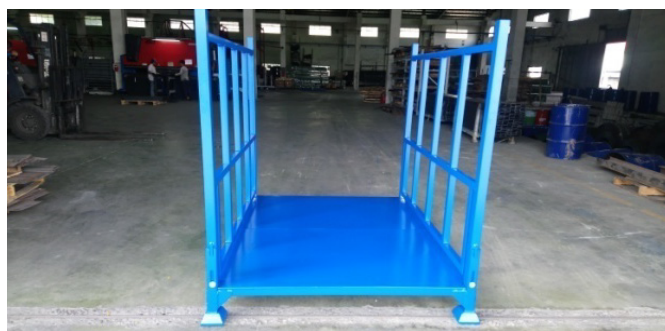
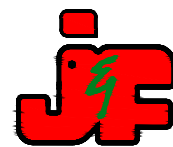

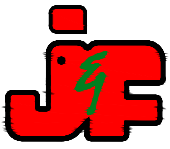

Boltless angle Racking Systems / Dạng kệ trữ hàng không bu lông

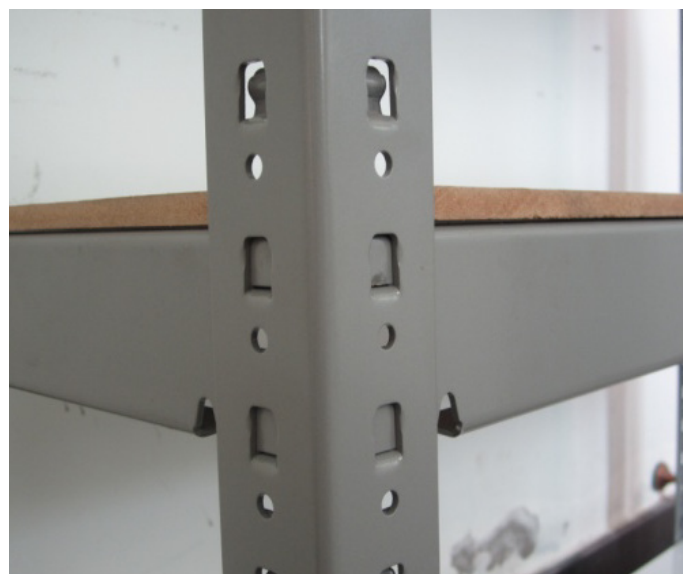

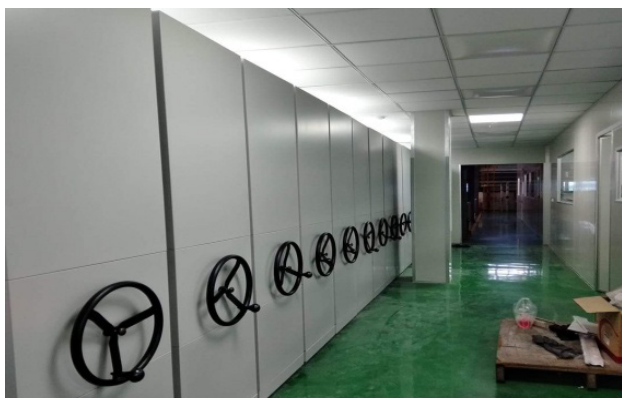
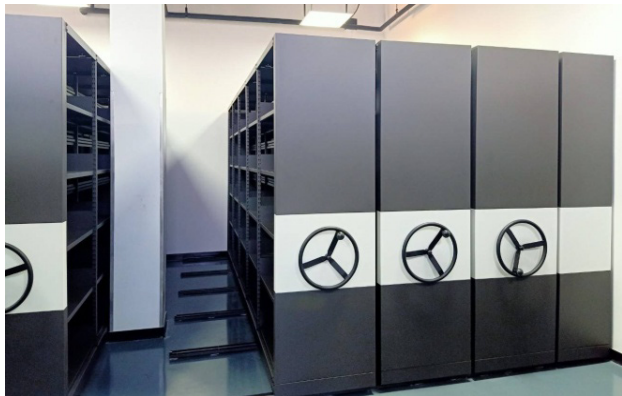

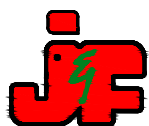

J & F INDUSTRIES INTERNATIONAL CO.,LTD

CÔNG TY TNHH QUỐC TẾ J&F

C2-18, DA DEN INDUSTRIAL ZONE, PHU TAN WARD, THU DAU MOT CITY, BINH DUONG PROVINCE, VIETNAM

LÔ C2-18, KCN ĐẠI ĐĂNG, PHƯỜNG PHÚ TÂN, THÀNH PHỐ THỦ DẦU MỘT, TỈNH BÌNH DƯƠNG, VIỆT NAM

TEL: 84 – 274 – 3624200

FAX: 84 – 274 – 3624201

E-mail: bd@jfrack.com